

ZPC - EPOXY AND ZINC COATED CAST IRON HUBLESS BEND AND CROSS TEE



COMPLY WITH BS EN877: 2021
BS EN 598: 2007

COATING CHARACTERISTIC

ITEM	LAYERS	THICKNESS
1	Internal Coating	Min. 250µm
2	A Lay Of Metallic Zinc	130g/m ²
3	External Coating	Average thickness ≥70µm, local minimum thickness not less than 50µm

4"X2"X90 DEG BEND

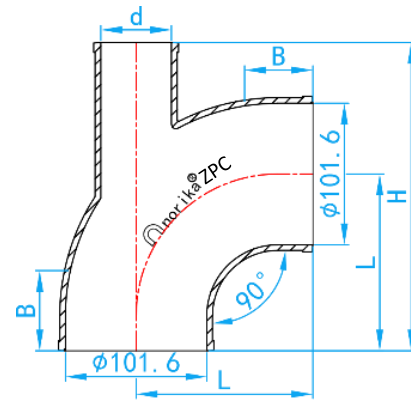

CROSS SECTIONAL VIEW

DIMENSIONS

SKU	SIZE (mm)	B (mm)	L (mm)	d (mm)	H (mm)	WEIGHT (kg)
HUBZB9010050	100X50	35	125	50.8	218	2.50

CROSS TEE 88°

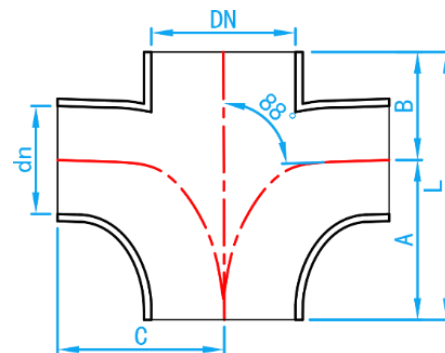

CROSS SECTIONAL VIEW

DIMENSIONS

SKU	DN (mm)	dn (mm)	A (mm)	B (mm)	L (mm)	C [mm]	WEIGHT (kg)
HUBZCT10050	100	50	100	80	180	105	2.21
HUBZCT100100	100	100	120	110	230	120	3.26
HUBZCT150100	150	100	130	115	245	145	5.15

Notes: The tolerance for Weight is ±10%.